



TILES

Our Tiles™ systems furniture offers customization at its best with six different panel options – glass, metal, rail, laminate, fabric, and whiteboard



 www.friant.com/tiles



furnishing excellence™



With Tiles™, Friant offers a frame and tile system with enhanced structural integrity, ease of installation, and unlimited design possibilities.

We've upgraded this solid steel frame and tile system for enhanced durability, longevity and easy reconfiguration. Tiles™ offers a superior sound experience with full accoustical tiles that are also tackable. Power and data are available at beltline or baseline, with a large cable lay-in capability.

Available in a variety of sizes and materials to allow for creative freedom in designing all your workspaces.

FABRICS

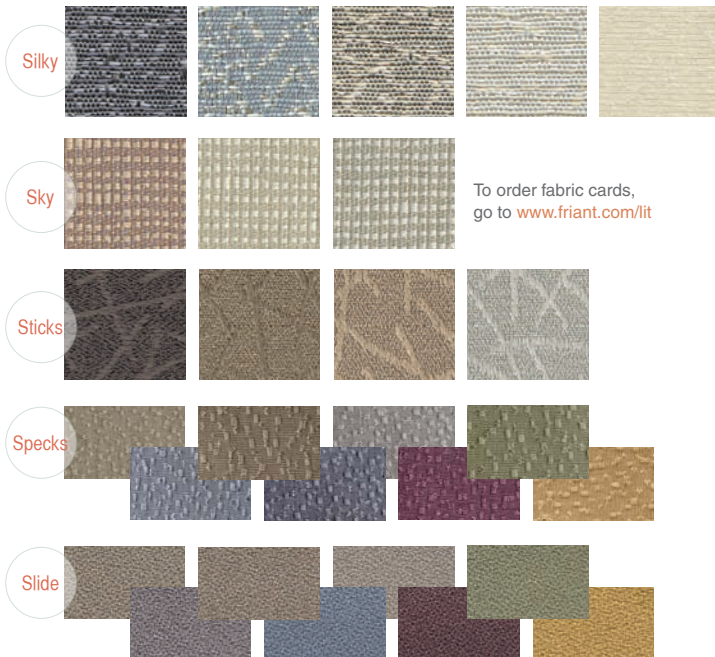

WORKSURFACES



END PANELS & EDGE FINISHES

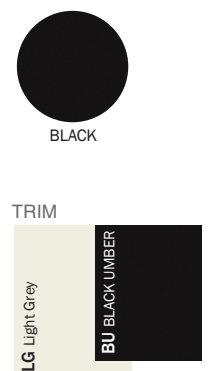

TRIM

Additional colors available – visit our web site for complete list www.friant.com/laminates

Typicals Tiles™ can easily be customized to suit your company's changing needs – below are just a few of the configurations possible with Tiles™.

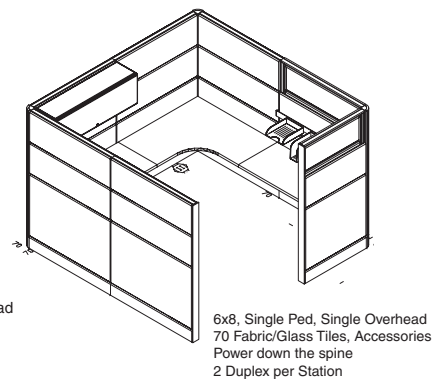
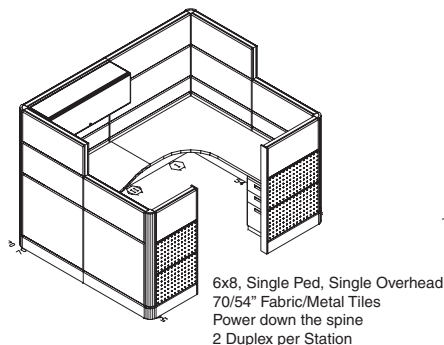
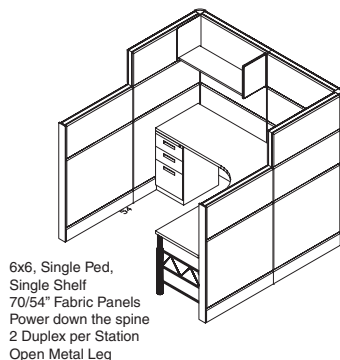

Contact your Sales Representative for pricing. To find a rep near you, go to www.friant.com/rep

www.friant.com/tiles